

Project:



Scan for more info!

Owners manual
Quick install
Quick sizing
Install layout
Parts list

CR-1
Compact countertop



Sparkling and chilled still water on tap

- Cold carbonation for better long lasting sparkling water
- Flow control faucets for sparkling & chilled still water
- European design, mirrored finish stainless steel exterior
- Made in the USA

Specifications

- 50 liters per hour @ 40°
- Self-contained refrigeration system
- Compressor: 1/5 H.P.
- Refrigerant: R134a CFC-free
- BTU: 2,200 per hour Ave
- Operating temperature range: 40° - 100°
- Electrical: 120v - 10.1 minimum amps
- Minimum circuit breaker size: 15 amps
- Carbonator: 1/3 H.P.
- Water bath: 4 Gallons
- Ice bank: 9.5 lbs
- Weight: 115 lbs
- Bottle filling clearance: 12"
- 12"W x 31"D x 24.5"H

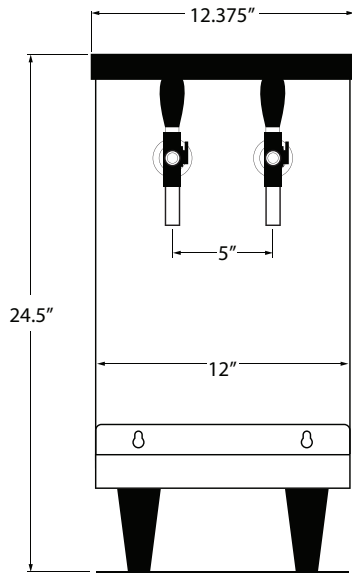

- 3/8" Water inlet connector
- 7' Over flow drain hose
- 7' CO2 hose 1/4" flare fitting
- 9' Electrical cord NEMA 5-15
- 4.0" - 5.5" legs

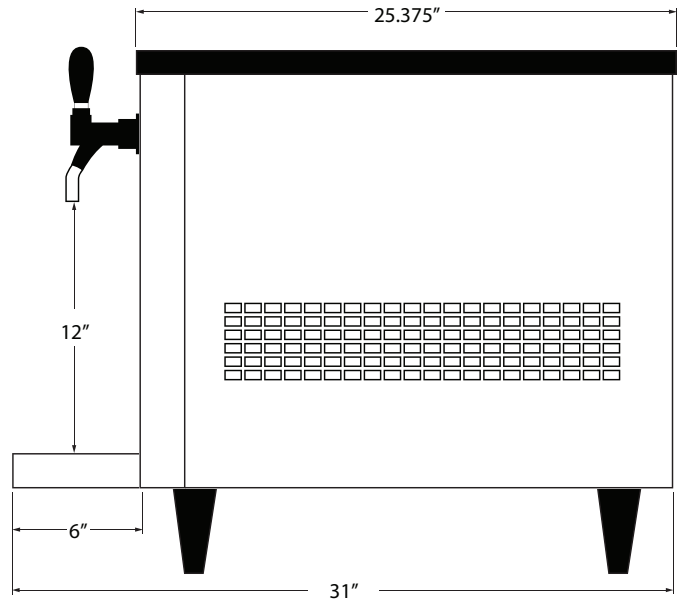

- Air intake at rear with air filter
- Allow for 6" rear & side clearance around unit for air flow
- Allow for 3" of rear clearance for connections

Accessories:

- CR-24FCP with prefilter
- CR-24FC without prefilter

Twin filter system with compact fibredyne filters, 19"H x 17"W 5 gpm, 30,000 gal, TOC & 1/2 micron filtration



- CR-SDL-1

Single sanitary dispense lever that attaches to a self closing faucet on unit. 1 per faucet. Great for self-service hands-free dispensing applications.



- CR-KIT-CT

Installation kit for countertop units, CR-1 & CR-2, includes: fittings and oetiker clamps and extra tubing to install the filter systems and countertop unit



- Customer supplied CO2 tank required

- CR-3741

Primary high pressure CO2 regulator for CO2 tank



- Available: CR-1-3V; 3-valve configured model - sparkling, chilled still, and ambient

