

Bag-In-Box Flat Rack Vertical Feed 3/4 Box 39" Wide



R03-03FV
BIB Rack Shelf



R03-03TS
Top Shelf

High quality BIB rack modular components provide strength and reliability.

Features

- Glide panels on shelves make pump installation and pump replacement easy.
- Hose management holes in the shelf's front and rear rail prevent tube kinking that restricts syrup flow and makes BIB pumps work harder. Each oval hole accommodates two 3/8" BIB tubes.
- 4" shelf leg connectors enhance the stability of stacked shelves.
- NSF approved.

Heavy Duty Construction

- Durable high gloss black powder coat paint resists rust.
- Top shelf can hold up to 275 lbs.

Pre-assembled rack systems are our specialty! Pumps, brackets, manifolds, fittings, tubing, connectors, bag selectors and regulators can be customized to your specifications. Call for details.

39" Wide Vertical BIB Rack Specifications

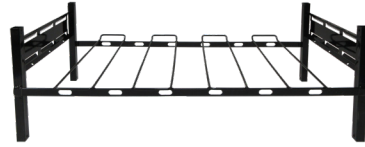

	BIB Rack Shelf	Top Shelf
Part Number	R03-03FV	R03-03TS
Width	39"	39"
Depth	17"	17"
Height	14"	8.5"
Weight Capacity	200 lbs	275 lbs
Shipping Weight	11 lbs	17 lbs

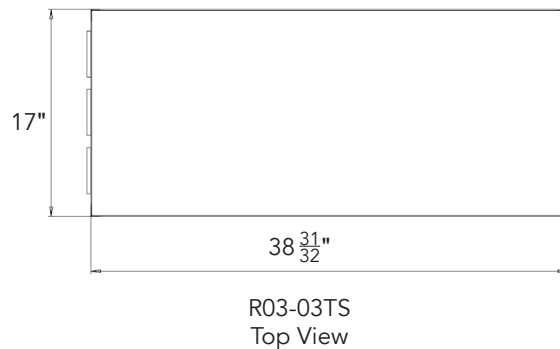
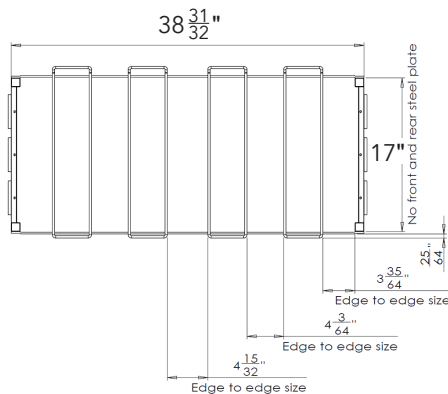
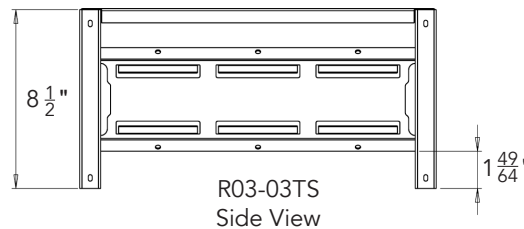
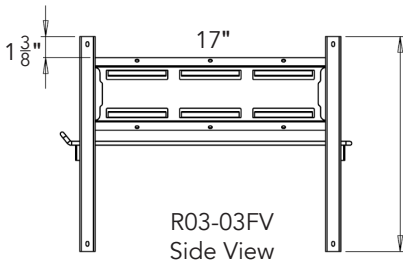
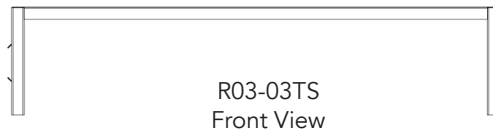
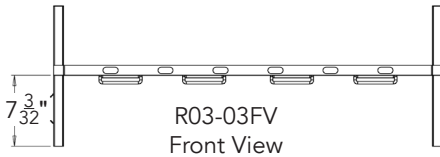

Accessories

- Shelf leg connectors
- End caps
- Casters
- Flojet or Shurflo pumps
- Pump glide brackets
- Transfer valves
- Auto shut-off valves
- Vacuum regulators
- In-line strainers
- BIB connectors
- CO₂ Regulators
- Tubing
- Fittings
- Clamps
- Cable ties

DISPENSING *Refreshing* RESULTS